

# R60CR-9A SPECIFICATIONS

**Net Power** 63 hp  
(47 kW) at  
2,200 rpm

**Operating Weight**  
6,100 kg (13,450 lb)

**Bucket Breakout Force**  
(ISO) 4,170 kgf /  
9,190 lbf

**Arm Digging Force**  
(ISO) 2,700 kgf /  
5,950 lbf

## ENGINE

MODEL	YANMAR 4TNV98C		
Type	Water-cooled, 4-cycle diesel 4 cylinders in line, direct injection, low emission		
Rated flywheel horsepower	SAE	J1995 (gross)	64.7 HP (48.3 kW) at 2,200 rpm
		J1349 (net)	63 HP (47.0 kW) at 2,200 rpm
Max. torque	24 kgf·m (174 lbf·ft) at 1,560 rpm		
Bore X stroke	98 mm (3.86") x 110 mm (4.33")		
Piston displacement	3,319 cc (203 in <sup>3</sup> )		
Battery	1 x 12 V x 100 Ah		
Starting motor	12 V - 3.0 kW		
Alternator	12 V - 80 Amp		

## HYDRAULIC SYSTEM

MAIN PUMP	
Type	Variable displacement piston pumps + gear pump
Max. flow	2 x 55 ℓ/min (14.5 gpm) + 36.6 ℓ/min (9.6 gpm) at 2,000 rpm
Sub-pump for pilot circuit (Gear pump)	6.9 ℓ/min (2.4 gpm)

## CROSS-SENSING AND FUEL-SAVING PUMP SYSTEM

HYDRAULIC MOTORS	
Travel	Two-speed axial piston motor with counter balance valve and parking brake
Swing	Axial piston motor with automatic brake

## RELIEF VALVE SETTING

Implement circuits	240 kgf/cm <sup>2</sup> (3,410 psi)
Travel circuit	220 kgf/cm <sup>2</sup> (3,130 psi)
Swing circuit	220 kgf/cm <sup>2</sup> (3,130 psi)
Pilot circuit	30 kgf/cm <sup>2</sup> (430 psi)
Service valve	Installed

## HYDRAULIC CYLINDERS

No. of cylinders bore X stroke	Boom: 1-110 x 715 mm (4.3" x 28.1")
	Arm: 1-85 x 840 mm (3.3" x 33.1")
	Bucket: 1-80 x 660 mm (3.1" x 26.0")
	Boom swing: 1-95 x 519 mm (3.7" x 20.4")
	Dozer blade: 1-110 x 224 mm (4.3" x 8.8")

## TRAVEL SYSTEM

Drive method	Full hydrostatic type
Drive motor	Axial piston motor, in-shoe design
Reduction system	Planetary reduction gear
Max. drawbar pull	5,300 kgf (11,700 lbf)
Max. travel speed (high) / (low)	4.0 km/hr (2.5 mph) / 2.2 km/hr (1.4 mph)
Gradeability	35° (70%)
Parking brake	Multi-wet disc

## CONTROLS

Pilot-pressure-operated joysticks and pedals with detachable lever provide almost effortless and fatiguesless operation.

Pilot control	Two joysticks with one safety lever (LH): Arm swing, Boom swing (RH): Boom and bucket (ISO)
Traveling and steering	Two levers with pedals
Engine throttle	Electric, dial type

## SWING SYSTEM

Swing motor	Axial piston motor
Swing reduction	Planetary gear reduction
Swing bearing lubrication	Grease-bathed
Swing brake	Multi wet disc
Swing speed	8.8 rpm

## COOLANT AND LUBRICANT CAPACITY

(Refilling)	liter	gal
Fuel tank	82.0	21.7
Engine coolant	11.0	2.9
Engine oil	11.6	3.1
Final drive (each)	1.2	0.3
Hydraulic tank	60.0	15.9
Hydraulic system	110.0	29.1

## WEIGHT (APPROXIMATE)

Operating weight 6,100 kg (13,450 lb), including 2,900 mm (9' 6") boom, 1,480 mm (4' 10") arm, SAE heaped 0.18 m<sup>3</sup> (0.24 yd<sup>3</sup>) excavator bucket, 400 mm (15.8") rubber track, lubricant, coolant, full fuel tank, hydraulic tank, 670 kg (1,480 lb) counterweight and the standard equipment.

Operating weight (cab)	6,100 kg (13,450 lb)
Ground pressure (cab)	0.35 kg/cm <sup>2</sup> (4.98 psi)

## UNDERCARRIAGE

X-leg type center frame is integrally welded with reinforced box-section track frames. The undercarriage includes lubricated rollers, track adjusters with shock absorbing springs and sprockets, and track chain with triple grouser shoes.

Center frame	X-leg type
Track frame	Pentagonal box type
No. of track shoes on each side	40
No. of upper rollers on each side	1
No. of lower rollers on each side	5

## R60CR-9A Lifting Capacity ISO Condition 2



Rating over front



Rating over side or 360 degrees

Boom: 2.9 m (9' 6") / Arm: 1.48 m (4' 10") / Bucket: 0.18 m<sup>3</sup> (0.24 yd<sup>3</sup>) SAE heaped / Dozer down / Counterweight 670 kg (1,480 lb)

Lift-point height m (ft)		Lift-point radius										At max. reach								
		2.0 m (6.6 ft)		2.5 m (8.2 ft)		3.0 m (9.8 ft)		3.5 m (11.5 ft)		4.0 m (13.1 ft)		4.5 m (14.8 ft)		5.0 m (16.4 ft)		Capacity	Reach			
4.0 m	kg							*1,300	*1,300	*1,370	1,060						*1,200	990	4.15	
13.1 ft	lb							*2,870	*2,870	*3,020	2,340						*2,650	2,190	(13.6)	
3.0 m	kg							*1,440	1,300	*1,400	1,050	*1,380	870				*1,110	770	4.81	
9.8 ft	lb							*3,180	2,870	*3,090	2,320	*3,050	1,910				*2,450	1,700	(15.8)	
2.0 m	kg							*2,240	1,560	*1,650	1,010	*1,510	840	*1,430	710		*1,120	680	5.13	
6.6 ft	lb							*4,930	3,450	*4,110	2,720	*3,630	2,220	*3,340	1,860	*3,160	1,570	*2,470	1,500	(16.8)
1.0 m	kg							*2,950	1,450	*2,310	1,160	*1,930	960	*1,690	810	*1,520	690	*1,200	650	5.20
3.3 ft	lb							*6,510	3,190	*5,090	2,560	*4,250	2,120	*3,720	1,780	*3,350	1,530	*2,640	1,440	(17.1)
0.0 m	kg			*2,150	1,860	*3,150	1,400	*2,510	1,120	*2,080	930	*1,780	790	*1,540	680	*1,380	680	*1,380	670	5.03
0.0 ft	lb			*4,750	4,100	*6,940	3,090	*5,530	2,470	*4,580	2,050	*3,920	1,730	*3,380	1,500	*3,050	1,480	*3,050	1,480	(16.5)
-1.0 m	kg	*2,870	2,800	*3,690	1,870	*2,930	1,400	*2,390	1,110	*1,990	920	*1,640	780				*1,570	760	4.59	
-3.3 ft	lb	*6,330	6,160	*8,140	4,120	*6,470	3,080	*5,270	2,450	*4,380	2,030	*3,610	1,730				*3,460	1,680	(15.1)	
-2.0 m	kg	*3,590	2,850	*2,810	1,910	*2,270	1,430	*1,820	1,140								*1,570	1,040	3.75	
-6.6 ft	lb	*7,920	6,290	*6,200	4,210	*5,010	3,150	*4,000	2,510								*3,460	2,280	(12.3)	

Notes:

1. Lifting capacities are based on ISO 10567.

2. Lifting capacities of the 9A Series do not exceed 75% of tipping load with the machine on firm, level ground or 87% of full hydraulic capacity.

3. The lift-point is a hook (standard equipment) located on the back of the bucket.

4. (\*) indicates load limited by hydraulic capacity.

# DIMENSIONS & WORKING RANGE

## R60CR-9A DIMENSIONS

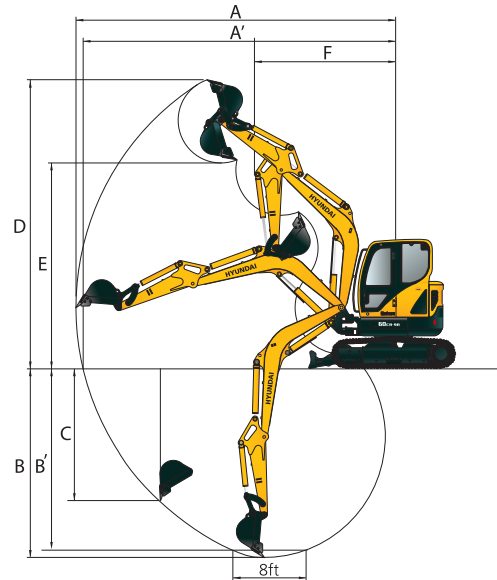
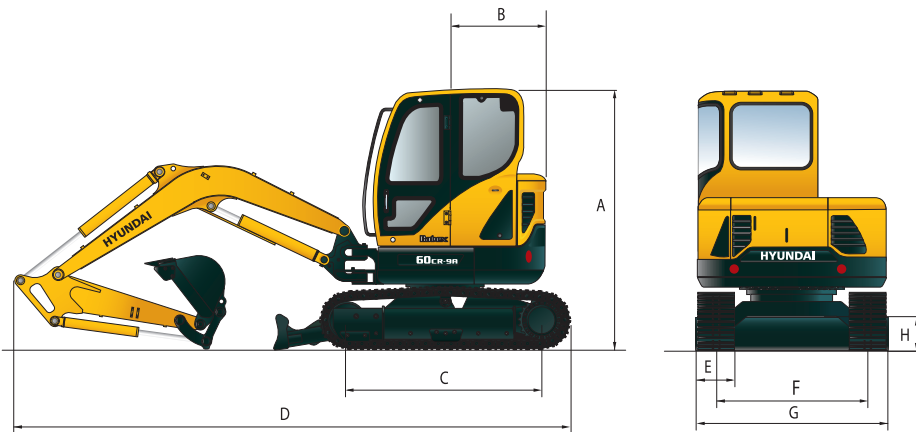

### R60CR-9A DIMENSIONS

		mm (ft-in)	
A	Overall height of cab	2,550 (8' 4")	
B	Tail swing radius	1,080 (3' 7")	
C	Tumbler distance	1,990 (6' 6")	
D	Overall length	5,600 (18' 4")	
E	Track shoe width	Steel	380 (1' 3")
		Rubber	400 (1' 4")
F	Track gauge	1,600 (5' 3")	
G	Overall width	2,000 (6' 7")	
H	Ground clearance	380 (1' 3")	

### BUCKETS

Capacity		Width		Weight
SAE heaped	CECE heaped	Without side cutters	With side cutters	
0.07 m <sup>3</sup> (0.09 yd <sup>3</sup> )	0.06 m <sup>3</sup> (0.08 yd <sup>3</sup> )	315 mm (12.4")	360 mm (14.2")	115 kg (255 lb)
0.18 m <sup>3</sup> (0.24 yd <sup>3</sup> )	0.15 m <sup>3</sup> (0.20 yd <sup>3</sup> )	670 mm (26.4")	740 mm (29.1")	170 kg (375 lb)

### R60CR-9A WORKING RANGE

		mm (ft-in)	
Boom length		2,900 (9' 6")	
Arm length		1,480 (4' 10")	1,900 (6' 3")
A	Max. digging reach	6,150 (20' 2")	6,480 (21' 3")
A'	Max. digging reach on ground	6,010 (19' 9")	6,350 (20' 10")
B	Max. digging depth	3,570 (11' 9")	3,990 (13' 1")
B'	Max. digging depth (8 ft)	3,160 (10' 5")	3,620 (11' 11")
C	Max. vertical wall digging depth	3,040 (9' 12")	3,360 (11' 0")
D	Max. digging height	5,680 (18' 8")	5,850 (19' 2")
E	Max. dumping height	3,930 (12' 11")	4,100 (13' 5")
F	Min. swing radius	2,420 (7' 11")	2,510 (8' 3")

### STANDARD EQUIPMENT

#### ISO standard cabin

- Cabin TOPS ISO 12117 (ROPS ISO 12117-2) FOG ISO 10262 Level I (FOPS ISO 3449 Level I)
- All-weather steel cab with all-around visibility
- Safety glass windows
- Rise-up type windshield wiper
- Sliding fold-in front window
- Sliding side window
- Lockable door
- Accessory box and ashtray

#### Air-conditioner and heater

- Travel alarm
- Quick coupler with piping

#### Centralized monitoring

- Engine speed
- Gauges
- Fuel-level gauge
- Engine coolant temperature gauge
- Warning Indicators**
- Fuel level
- Engine oil pressure
- Engine coolant temperature
- Hydraulic oil temperature
- Low battery
- Air cleaner clogging
- Fuel prefilter

#### Rubber track shoes (400 mm / 1' 4")

- Pattern-change lever
- Additional counterweight (200 kg / 440 lb)
- Door and cab locks, one key
- Radio / USB player with remote control

#### Outside rearview mirror

- Single-acting piping kit (breaker, etc)
- Double-acting piping kit (clamshell, etc.)
- Fully adjustable suspension seat with seat belt
- Console box tilting system (LH)
- Two front working lights
- Electric horn
- Battery (1 x 12 V x 100 Ah)
- Battery master switch
- 12-volt power supply
- Automatic swing brake
- Removable reservoir tank
- Water separator, fuel line
- Mono boom (2.9 m / 9' 6")
- Arm (1.48 m / 4' 10")
- Track rail guard
- Starting aid (air grid heater) cold weather
- Hyundai bucket (0.18 m<sup>3</sup> / 0.24 yd<sup>3</sup>)

### OPTIONAL EQUIPMENT

- Beacon lamp
- Accumulator
- Long arm (1.9 m / 6'3")

- Tool kit
- Cabin rear work lamp
- Safety lock v/v for boom cylinder with overload warning

- Safety lock v/v for arm cylinder
- Steel track shoes (380 mm / 14")
- Rearview camera

Specifications and features are subject to change without notice. Pictures may show options other than standard equipment.



6100 Atlantic Blvd., Norcross, GA 30071  
TEL (678) 823-7777 FAX (678) 823-7778



Printed in U.S.A.



R60CR-9A 7/2023 PS v1