

SPECIFICATIONS

HX210A L

Powered By Cummins Performance Series Engine



Net Power
170 HP (127 kW)
/ 2,200 rpm

Standard Bucket
0.92 m³ / 1.2 yd³

Operating Weight
22,150 kg (48,830 lb) -
23,170 kg (51,080 lb)

ENGINE

Maker / Model	CUMMINS / B4.5
Type	Tier 4F/ Stage V Emission Certified, 4 cylinder diesel engine with no manual regeneration.
Gross power	129 kW (173 hp) at 2,200 rpm
Net power	127 kW (170 hp) at 2,200 rpm
Max. power	142 kW (190 hp) at 2,000 rpm
Peak torque	780 N·m (575 lb·ft) at 1,500 rpm
Displacement	4.5 l (275 cu in)

HYDRAULIC SYSTEM

MAIN PUMP

Type	Variable Displacement Tandem Axis Piston Pumps
Max. flow	2 x 61.8 gpm (2 x 234 l/min)
Sub-Pump for pilot circuit	Gear Pump

Cross-sensing and fuel saving pump system.

AUXILIARY PRESSURE

2 Way	Flow (l/min)	26~116 gpm / (100~440 lpm)
	Pressure (bar)	1,450~5,076 psi / (100~350 bar)
Rotating	Flow (l/min)	10 gpm / (37.8 lpm)
	Pressure (bar)	2,321 psi / (160 bar)

HYDRAULIC MOTORS

Travel	Two speed axial pistons motor with brake valve and parking brake
Swing	Axial piston motor with automatic brake

RELIEF VALVE SETTING

Implement circuits	350 kgf/cm ² (4,980 psi)
Travel	350 kgf/cm ² (4,980 psi)
Power boost (Boom, Arm, Bucket)	380 kgf/cm ² (5,400 psi)
Swing circuit	265 kgf/cm ² (3,770 psi)
Pilot circuit	40 kgf/cm ² (570psi)
Service valve	Installed

HYDRAULIC CYLINDERS

No. of Cylinder Bore X Stroke	Boom: Ø120x1,290 mm
	Arm: Ø140x1,510 mm
	Bucket: Ø120x1,055 mm

* Hyundai Bio Hydraulic Oil (HBHO) available.

DRIVES & BRAKES

Drive method	Fully Hydrostatic Type
Drive motor	Axial Piston Motor, In-Shoe Design
Reduction system	Planetary Reduction Gear
Max. Drawbar pull	20,800 kgf (45,860 lbf)
Max. Travel speed (High / Low)	5.8 km/hr (3.6 mph) / 3.7 km/hr (2.3 mph)
Gradeability	35°(70%)
Parking brake	Multi Wet Disc

CONTROL

Pilot pressure operated joysticks and pedals with detachable lever provide almost effortless and fatigueless operation.

Pilot control	Two Joysticks with One Safety Lever (LH): Swing and Arm, Boom and Bucket
Traveling and Steering	Two Levers With Pedals
Engine throttle	Electric, Dial Type

OPERATING WEIGHT (APPROXIMATE)

Operating weight, including 5,690 mm (18' 8") boom, 2,920 mm (9' 7") arm, SAE heaped 0.92 m³ (1.2 yd³) bucket, lubricant, coolant, full fuel tank, full hydraulic tank, and all standard equipment.

Shoes		Operating Weight		Ground Pressure
Type	Width mm (in)	kg (lb)		kgf/cm ² (psi)
	600 (24")	HX210A L	22,150 (48,830)	0.47 (6.71)
	700 (28")	HX210A L	22,620 (49,870)	0.41 (5.87)
	800 (32")	HX210A L	22,890 (50,460)	0.37 (5.20)
	900 (36")	HX210A L	23,170 (51,080)	0.33 (4.68)
Double grouser	700 (28")	HX210A L	22,880 (50,440)	0.42 (5.94)

SWING SYSTEM

Swing motor	Fixed Displacement Axial Piston Motor
Swing reduction	Planetary Gear Reduction
Swing bearing lubrication	Grease-Bathed
Swing brake	Multi Wet Disc
Swing speed	12 rpm

CAPACITIES

	liter	US gal
Fuel tank	400	106
Engine coolant	40	10.6
Engine oil	23.1	6.1
Swing device	6.2	1.64
Final drive (Each)	4.5	1.2
Hydraulic system (Including Tank)	275	72.6
Hydraulic tank	155	40.9
DEF/AdBlue®	48	12.6

UNDERCARRIAGE

The X-leg type center frame is integrally welded with reinforced box-section track frames. The undercarriage includes lubricated rollers, idlers, track adjusters with shock absorbing springs and sprockets, and a track chain with double or triple grouser shoes.

Center frame	X-Leg Type
Track frame	Pentagonal Box Type
No. of Shoes on each side	49 EA
No. of Carrier roller on each side	2 EA
No. of Track roller on each side	9 EA
No. of Rail guard on each side	2 EA

CAB NOISE LEVEL

Guaranteed noise level presented below can be differed depending on a range of factors such as operating condition, speed of a cooling fan, types of engine and so forth. Hearing protection may be necessary if an operator is working in the improperly aintained cabin or exposed to a noisy environment by leaving doors and/or windows open. With cooling fan speed at maximum value:

Operator sound pressure level (ISO 6396:2008)	70 dB(A)
Exterior sound power level (ISO 6395:2008)	98 dB(A)

* Distance of 15 m (49.2 ft), moving forward in second gear ratio

SPECIFICATIONS HX210A L

Powered By Cummins Performance Series Engine

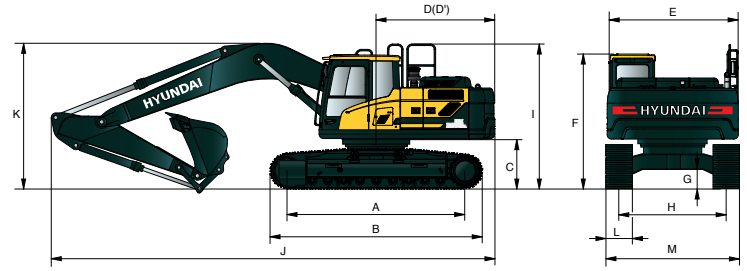

HX210A L DIMENSIONS

Unit: mm (ft.-in)

5,690 mm (18' 8") BOOM and 2.0m (6' 7"), 2.4m (7' 10"), 2.92m (9' 7"), 3.9m (12' 10") ARM

A	Tumbler Distance	3,650 (12' 0")
B	Overall Length of Crawler	4,404 (14' 4")
C	Ground Clearance of Counter weight	1,060 (3' 6")
D	Tail Swing Radius	2,850 (9' 4")
D'	Rear-End Length	2,770 (9' 1")
E	Overall Width of Upperstructure	2,530 (8' 3")
F	Overall Height of Cab	3,000 (9' 8")
G	Min. Ground Clearance	470 (1' 7")
H	Track Gauge	2,390 (7' 10")
I	Overall Height of Guardrail	3,210 (10' 5")

Boom Length	5,690 (18' 8")				
Arm Length	2,000 (6' 7")	2,400 (7' 10")	2,920 (9' 7")	3,900 (12' 10")	
J Overall Length	9,650 (31' 8")	9,570 (31' 5")	9,510 (31' 2")	9,480 (31' 1")	
K Overall Height of Boom	3,250 (10' 8")	3,170 (10' 5")	3,100 (10' 2")	3,500 (11' 6")	
L Track Shoe Width	TRIPLE GROUSER				DOUBLE GROUSER
	600 (24")	700 (28")	800 (32")	900 (35")	700 (28")
M Overall Width	2,990 (9' 10")	3,090 (10' 2")	3,190 (10' 6")	3,290 (10' 10")	3,090 (10' 2")

HX210A L WORKING RANGE

Unit : mm (ft.-in)

Boom Length	5,690 (18' 8")			
Arm Length	2,000 (6' 7")	2,400 (7' 10")	2,920 (9' 7")	3,900 (12' 10")
A Max. Digging Reach	9,140 (30' 0")	9,500 (31' 2")	9,960 (32' 8")	10,900 (35' 9")
A Max. Digging Reach on Ground	8,960 (29' 5")	9,340 (30' 8")	9,800 (32' 2")	10,750 (35' 3")
B Max. Digging Depth	5,750 (18' 10")	6,150 (20' 2")	6,640 (21' 9")	7,610 (25' 0")
B Max. Digging Depth (8' Level)	5,520 (18' 1")	5,950 (19' 6")	6,470 (21' 3")	7,460 (24' 6")
C Max. Vertical Wall Digging Depth	5,320 (17' 5")	5,780 (19' 0")	6,250 (20' 6")	6,940 (22' 9")
D Max. Digging Height	9,270 (30' 5")	9,500 (31' 2")	9,740 (31' 11")	10,310 (33' 10")
E Max. Dumping Height	6,450 (21' 2")	6,660 (21' 10")	6,900 (22' 8")	7,470 (24' 6")
F Min. Swing Radius	3,710 (12' 2")	3,630 (11' 11")	3,580 (11' 9")	6,850 (22' 6")

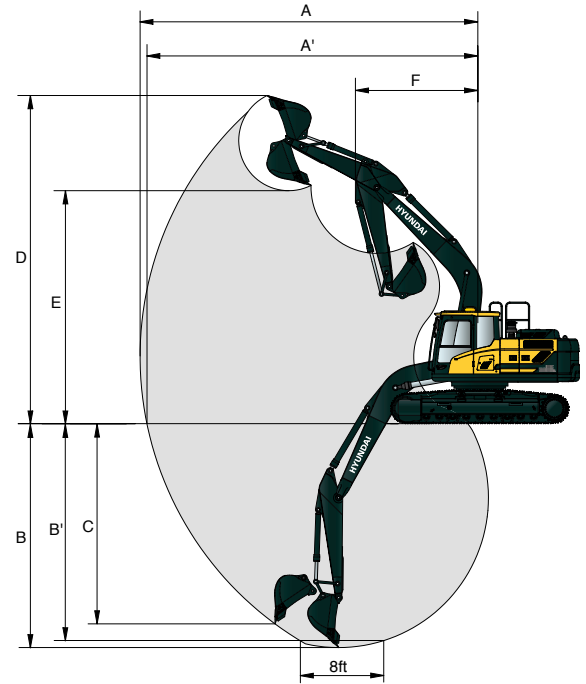

HX210A L DIGGING FORCE

Boom	Length	mm (ft.in)	5,690 (18' 8")				Power Boost
	Weight	kg (lb)	1,950 (4,300) & 2,600 (5,730)				
Arm	Length	mm (ft.in)	2,000 (6' 7")	2,400 (7' 10")	2,920 (9' 7")	3,900 (12' 10")	Power Boost
	Weight	kg (lb)	975 (2,150)	1,045 (2,300)	1,095 (2,410)	1,295 (2,850)	
Bucket Digging Force	SAE	kN	133.4 [144.8]	133.4 [144.8]	133.4 [144.8]	133.4 [144.8]	
		kgf	13,600 [14,770]	13,600 [14,770]	13,600 [14,770]	13,600 [14,770]	
		lbf	29,980 [32,560]	29,980 [32,560]	29,980 [32,560]	29,980 [32,560]	
	ISO	kN	152.0 [165.0]	152.0 [165.0]	152.0 [165.0]	152.0 [165.0]	
		kgf	15,500 [16,830]	15,500 [16,830]	15,500 [16,830]	15,500 [16,830]	
		lbf	34,170 [37,100]	34,170 [37,100]	34,170 [37,100]	34,170 [37,100]	
Arm Crowd Force	SAE	kN	144.2 [156.5]	119.6 [129.9]	102.0 [110.7]	84.3 [91.6]	
		kgf	14,700 [15,960]	12,200 [13,250]	10,400 [11,290]	8,600 [9,340]	
		lbf	32,410 [35,190]	26,900 [29,210]	22,930 [24,890]	18,960 [20,590]	
	ISO	kN	151.0 [164.0]	125.5 [136.3]	106.9 [116.0]	87.3 [94.7]	
		kgf	15,400 [16,720]	12,800 [13,900]	10,900 [11,830]	8,900 [9,660]	
		lbf	33,950 [36,860]	28,220 [30,640]	24,030 [26,080]	19,620 [21,300]	

Note : Boom weight includes arm cylinder, piping, and pin Arm weight includes bucket cylinder, linkage, and pin.

SPECIFICATIONS HX210AL

Powered By Cummins Performance Series Engine

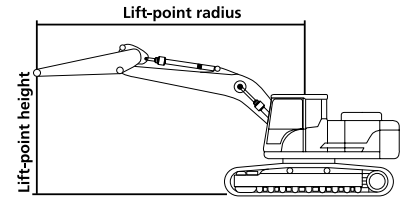

Lifting Capacity

Boom: 5,680 mm (18' 8")

Arm: 2,920 mm (9' 7")

Bucket: 0.92 m³ (1.2 yd³) SAE heaped

Shoe 800 mm (32") triple grouser, CWT 4,500 kg (9,920 lb)

Capacities based on North American Standard Configuration in accordance with ISO condition 2 standard.

Rating over front

Rating over side or 360 degrees

Lift-point height m (ft)		Lift-point radius										At max. reach		
		1.5 m (4.9 ft)		3.0 m (9.8 ft)		4.5 m (14.8 ft)		6.0 m (19.7 ft)		7.5 m (24.6 ft)		Capacity		Reach
														m (ft)
7.5 m	kg							*4250	*4250			*3190	*3190	6.24
24.6 ft	lb							*9370	*9370			*7030	*7030	
6.0 m	kg							*4440	*4440			*2920	*2920	7.36
19.7 ft	lb							*9790	*9790			*6440	*6440	(24.1)
4.5 m	kg							*4950	*4950	*4730	3950	*2840	*2840	8.05
14.8 ft	lb							*10910	*10910	*10430	8710	*6260	*6260	
3.0 m	kg					*7370	*7370	*5790	5370	*5090	3850	*2880	*2880	8.41
9.8 ft	lb					*16250	*16250	*12760	11840	*11220	8490	*6350	*6350	
1.5 m	kg					*9140	7690	*6690	5130	*5540	3730	*3040	*3040	8.49
4.9 ft	lb					*20150	16950	*14750	11310	*12210	8220	*6700	*6700	
Ground Line	kg			*6220	*6220	*10180	7410	*7360	4950	5660	3640	*3360	3170	8.30
	lb			*13710	*13710	*22440	16340	*16230	10910	12480	8020	*7410	6990	
-1.5 m	kg	*6700	*6700	*10680	*10680	*10430	7330	*7640	4880	5630	3620	*3920	3430	7.82
-4.9 ft	lb	*14770	*14770	*23550	*23550	*22990	16160	*16840	10760	12410	7980	*8640	7560	
-3.0 m	kg	*11310	*11310	*14370	*14370	*9920	7390	*7310	4910			*5050	4040	6.98
-9.8 ft	lb	*24930	*24930	*31680	*31680	*21870	16290	*16120	10820			*11130	8910	
-4.5 m	kg			*11800	*11800	*8290	7600			*6180		5580	5.63	5.65
-14.8 ft	lb			*26010	*26010	*18280	16760			*13620		12300	(18.5)	(18.5)

NOTES:

- Lifting capacities are based on ISO 10567.
- Lifting capacity of the HX Series does not exceed 75% of tipping load with the machine on firm, level ground or 87% of full hydraulic capacity.
- The Lift-point is the bucket pivot mounting pin on the arm (without bucket mass).
- (*) indicates load limited by hydraulic capacity.



ENGINE	STD	OPT
Cummins B4.5	•	
HYDRAULIC SYSTEM	STD	OPT
Electric Positive Flow Control (EPFC)		
3-Power Mode, 2-Work Mode, User Mode	•	
Variable Power Control	•	
Pump Flow Control	•	
Attachment Mode Flow Control	•	
Engine Auto Idle	•	
Automatic Swing Brake	•	
Engine Auto Shutdown Control	•	
Electronic Fan Control	•	
Hyundai Bio Hydraulic oil (HBHO)		•
CAB & INTERIOR	STD	OPT
ISO Standard cabin		
Rise-Up Type Windshield Wiper	•	
Radio / USB Player	•	
Handsfree Mobile Phone System with USB	•	
12V Power Outlet (24V DC to 12V DC converter)	•	
Electric Horn	•	
All-Weather Steel Cab with 360° Visibility	•	
Safety Glass - Tempered Glass	•	
Safety Glass - Laminated Glass, Front Window & Glass		•
Sliding Fold-In Front Window	•	
Sliding Side Window (LH)	•	
Lockable Door	•	
Hot & Cool Box	•	
Storage Compartment	•	
Ashtray & Cigar Lighter		•
Transparent Cabin Roof-Cover	•	
Sun Visor	•	
Door And Cab Locks, One Key	•	
Mechanical Suspension Seat With Heater	•	
Pilot-Operated Slidable Joystick	•	
Console Box Height Adjust System	•	
Automatic climate control		
Air Conditioner & Heater	•	
Defroster	•	
Starting Aid (Air Grid Heater) for Cold Weather	•	
Centralized monitoring		
8" LCD Display	•	
Engine Speed or Trip Meter / Accel.	•	
Engine Coolant Temperature Gauge	•	
Max Power	•	
Low Speed / High Speed	•	
Auto Idle	•	
Overload	•	
Check Engine	•	
Air Cleaner Clogging	•	
Indicators	•	
ECO Gauges	•	
Fuel Level Gauge	•	
Hyd. Oil Temperature Gauge	•	
Fuel Warmer	•	
Warnings	•	
Communication Error	•	
Low Battery	•	
Clock	•	
Cabin Lights	•	
Cabin Front Window Rain Guard		•
Cabin Roof-Steel Cover		•
Seat		
Adjustable Air Suspension Seat With Heater	•	
Cabin FOG (ISO 10262) Level 2		
FOG (Falling Object Protective Structure)-ISO 10262 Level 2		•

CAB & INTERIOR	STD	OPT
Cabin ROPS		
ROPS (Roll Over Protective Structures)-ISO 1211 7-2	•	
SAFETY	STD	OPT
Battery Master Switch	•	
Rearview Camera	•	
AAVM (Advanced Around View Monitoring)		•
Four Front Working Lights (2 Boom Mounted, 2 Front Frame Mounted)	•	
Travel Alarm	•	
Rear Work Lamp		•
Beacon Lamp		•
Automatic Swing Brake	•	
Boom Holding System	•	
Arm Holding System	•	
Safety Lock Valve For Boom Cylinder With Overload Warning Device		•
Safety Lock Valve For Arm Cylinder		•
Swing Lock System		•
Three Outside Rearview Mirrors	•	
Front Guard - Wire Net		•
ATTACHMENT	STD	OPT
Booms		
5.65 m, 18' 8" Mono	•	
Arms		
2.0 m, 6' 7"		•
2.4 m, 7' 10"		•
2.92 m, 9' 7"	•	
3.9 m, 12' 10"		•
OTHER	STD	OPT
Removable Clean-Out Dust Net For Cooler	•	
Removable Reservoir Tank	•	
Fuel Warmer	•	
Self-Diagnostics System	•	
Hi-MATE (Remote Management System)	•	
Batteries (2 x 12 V x 100 AH)	•	
Fuel Filler Pump (50 l/min)		•
Single-Acting Piping Kit (Breaker, Etc.)		•
Double-Acting Piping Kit (Clamshell, Etc.)	•	
2 way Proportional RCV & Pedal control selection	•	
Rotating Piping Kit		•
Quick Coupler Piping	•	
Quick Coupler	•	
One Pedal Straight Travel System	•	
Accumulator For Lowering Work Equipment	•	
Pattern Change Valve (2 Patterns)	•	
Fine Swing Control & Tool Kit		•
UNDERCARRIAGE	STD	OPT
Lower Frame Under Cover (Additional)		•
Lower Frame Under Cover (Normal)	•	
Track Shoes		•
Triple Grousers Shoes (500 mm, 20")		•
Triple Grousers Shoes (600 mm, 24")		•
Triple Grousers Shoe (700 mm, 28")		•
Triple Grousers Shoe (800 mm, 32")	•	
Triple Grousers Shoe (900 mm, 35")		•
Double Grousers Shoe (700 mm, 28")		•
Track Rail Guard	•	

* Standard and optional equipment may vary. Contact your Hyundai dealer for more information. The machine may vary according to international standards.

* The photos may include attachments and optional equipment that are not available in your area.

* Materials and specifications are subject to change without advance notice.

* All imperial measurements rounded off to the nearest pound or inch.



6100 Atlantic Blvd., Norcross, GA 30071
TEL (678) 823-7777 FAX (678) 823-7778



Printed in U.S.A.



HX210A L 8/2023 PS v1